



EVERPURE® INSURICE® PF QUAD 7FC-S SYSTEM

DELIVERS PREMIUM QUALITY WATER FOR HIGH CAPACITY ICE APPLICATIONS

Insurice PF Quad 7FC-S System: EV9327-74
7FC-S Replacement Cartridge (1 PK): EV9692-71
EC210 Prefilter Cartridge (6 PK): EV9534-26



APPLICATIONS

Ice

FEATURES • BENEFITS

Reduces ice machine problems caused by scale buildup from dirt and dissolved minerals*

Sanitary cartridge replacement is simple, quick and clean; internal filter parts are never exposed to handling or contamination

Reduces maintenance and service costs by reducing scale* and clogging of distribution lines, evaporator plate and pump

Proprietary Fibredyne™ II media inhibits the growth of bacteria on the filter media that can decrease product life

Exclusive Fibredyne II submicron carbon block technology provides superior chlorine taste and odor reduction and micro-filters dirt and particles as small as 0.5 micron in size by mechanical means

Balanced cartridge for optimum performance in varying water qualities

Integrated beaded phosphate

Manifold features water shut-off, flushing valve and outlet pressure gauge

Increased capacity for extended reduction of chemical and mechanical contaminants

20" prefilter reduces dirt and particles

NSF/ANSI Standard 53 certified to reduce cysts such as *Cryptosporidium* and *Giardia* by mechanical means

*As tested by Pentair

INSTALLATION TIPS

Choose a mounting location suitable to support the full weight of the system when operating.

Never use a saddle valve for connection.

Use 3/4" water line.

Do not connect system to water-cooled condenser.

Install vertically with cartridges hanging down and allow 2 1/2" (6.35 cm) clearance below the cartridge for easy cartridge replacement.

Flush cartridges by running water through system for five (5) minutes at full flow.

OPERATION TIPS

Replace cartridge when flow rate becomes inconveniently slow or before rated capacity is reached. It is recommended to replace cartridge at least once per year.

Change cartridges when capacity is reached or when pressure falls below 10 psi (0.7 bar).

Always flush the filter cartridge at time of installation and cartridge change.

Inspect Everpure EC210 Cartridge periodically to determine dirt load.

Replace Everpure EC210 Cartridge when dirt has penetrated through to the inner core of the cartridge.

SIZING

Service Flow Rate: Maximum 10.0 gpm (37.85 Lpm)

Rated Capacity: 100,000 Gallons (378,541 L)

EVERPURE® INSURICE® PF QUAD 7FC-S SYSTEM EV9327-74

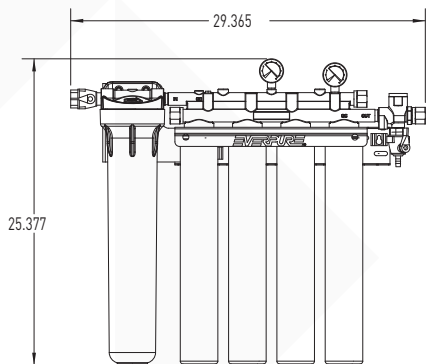

SPECIFICATIONS

Service Flow Rate

Maximum 10.0 gpm (37.85 Lpm)

Rated Capacity

100,000 gallons (378,541 L)

Pressure Requirements

10 - 125 psi (0.7 - 8.6 bar), non-shock

Maximum Temperature

35 - 100°F (2 - 38°C)

Overall Dimensions

25.59" H X 29.36" W X 6.75" D
(65 X 74.57 X 17.14 cm)

Inlet Connection

3/4"

Outlet Connection

3/4"

Electrical Connection

None required

Shipping Weight

43 lbs. (19.50 kg)

Operating Weight

55 lbs. (24.94 kg)



System Tested and Certified by NSF International against NSF/ANSI Standards 42 and 53 for the reduction of:

STANDARD NO. 42 –
AESTHETIC EFFECTS

- Bacteriostatic Effects
- Chemical Reduction
- Taste & Odor
- Chlorine

- Mechanical Filtration
- Nominal Particulate Class I

STANDARD NO. 53 –
HEALTH EFFECTS

- Mechanical Filtration
- Cyst
- Turbidity

EPA Est. No. 002623-IL-00

The contaminants or other substances removed or reduced by this drinking water system are not necessarily in your water. Do not use with water that is microbiologically unsafe or of unknown quality without adequate disinfection before or after the system. Systems certified for cyst reduction may be used with disinfected water that may contain filterable cysts.

WARRANTY

Everpure water treatment systems by Pentair® (excluding replaceable elements) are covered by a limited warranty against defects in material and workmanship for a period of five years after date of purchase. Everpure replaceable elements (filter cartridges and water treatment cartridges) are covered by a limited warranty against defects in material and workmanship for a period of one year after date of purchase. See printed warranty for details. Pentair will provide a copy of the warranty upon request.



WATER QUALITY SYSTEMS

EVERPURE-SHURFLO WORLD HEADQUARTERS, 1040 MUIRFIELD DRIVE, HANOVER PARK, IL 60133 USA • FOODSERVICE.PENTAIR.COM
800.942.1153 (US ONLY) • 630.307.3000 MAIN • 630.307.3030 FAX • CSEVERPURE@PENTAIR.COM EMAIL

EVERPURE-SHURFLO AUSTRALIA, 1-21 MONASH DRIVE, DANDENONG SOUTH, VIC 3175 AUSTRALIA
011.1300.576.190 TEL • 011.61.39.562.7237 FAX • AU.EVERPURE@PENTAIR.COM EMAIL

EVERPURE-SHURFLO CHINA, 21F CLOUD 9 PLAZA, NO 1118, SHANGHAI, 200052, CHINA
86.21.3211.4588 TEL • 86.21.3211.4580 FAX • CHINA.WATER@PENTAIR.COM EMAIL

EVERPURE-SHURFLO INDIA, GREEN BOULEVARD, B-9/A, 7TH FLOOR - TOWER B SECTOR 62, NOIDA - 201301
91.120.419.9444 TEL • 91.120.419.9400 FAX • INDIACUSTOMER@PENTAIR.COM EMAIL

EVERPURE-SHURFLO EUROPE, PENTAIR WATER BELGIUM BVBA, INDUSTRIEPARK WOLFSTEE, TOEKOMSTLAAN 30, B-2200 HERENTALS, BELGIUM
+32.(0).14.283.504 TEL • +32.(0).14.283.505 FAX • SALES@EVERPURE-EUROPE.COM EMAIL

EVERPURE-SHURFLO JAPAN INC., HASHIMOTO MN BLDG. 7F, 3-25-1 HASHIMOTO, MIDORI-KU, SAGAMIHARA-SHI KANAGAWA 252-0143, JAPAN
81.(0)42.775.3011 TEL • 81.(0)42.775.3015 FAX • INFO@EVERPURE.CO.JP EMAIL

EVERPURE-SHURFLO SOUTHEAST ASIA, 390 HAVELOCK ROAD, #04-01 KING'S CENTRE, SINGAPORE 169662
65.6768.5800 TEL • 65.6737.5149 FAX • CSEVERPURE@PENTAIR.COM EMAIL

All Pentair trademarks and logos are owned by Pentair, Inc. or its affiliates. All other registered and unregistered trademarks and logos are the property of their respective owners. Because we are continuously improving our products and services, Pentair reserves the right to change specifications without prior notice. Pentair is an equal opportunity employer.