

EZ-RO™ 650/16ATM REVERSE OSMOSIS SYSTEM

System Part Number: EV9975-70



EZ-RO 650/16ATM wall mount

EZ-RO 650/16ATM with optional floor stand bracket



16-gallon atmospheric tank

SYSTEM DESCRIPTION

Leveraging proprietary technology, the **EZ-RO 650/16ATM** system uses Reverse Osmosis (RO) to reduce Total Dissolved Solids (TDS); it provides up to 650 gal/day (2,460 L/day)* and includes a 16-gallon (60.6 L) atmospheric tank. Ideal for applications where RO is necessary to meet manufacturer's warranty requirements†.

APPLICATIONS

- ◆ Combi ovens
- ◆ Steamers
- ◆ Proofers

FEATURES • BENEFITS

- ◆ Meets combi oven and steamer equipment water quality standards; known to significantly reduce scale and corrosion problems due to high TDS, water hardness*, and chlorides†
- ◆ 7CM cartridge provides optimal mineral content for proper function of conductivity sensors on steam equipment
- ◆ Sealed atmospheric storage tank provides compact capacity and electronic pump delivers optimized water to downstream equipment
- ◆ Compact design allows installation under counters and in tight spaces
- ◆ Pressure gauge allows monitoring of RO inlet pressure and prefilter condition
- ◆ Built-in bypass, sample port and flush valves speed up installation and cartridge replacement
- ◆ Proprietary Fibredyne™ II filtration media effectively inhibits growth of bacteria on the filter media that can decrease product life. Also can reduce sediment and chlorine to help protect the RO membrane*
- ◆ High flow 1/2" ID hose optimized water line to equipment
- ◆ Installation kit comes complete with tubing, fittings, and mounting hardware for installation
- ◆ High efficiency RO membrane saves up to two times more water than standard RO membranes‡
- ◆ Numerous patents pending on technology and other aspects of the product design

INSTALLATION TIPS

- ◆ Feed water connection to system—should be COLD only. Tempered water up to 80°F (26.6°C) can be used.
- ◆ Do not exceed system specifications for temperature and pressure.
- ◆ Provide a dedicated feed water supply connection of at least 3/8" inner diameter.
- ◆ For use with steam generation only. Do not use for condensate or wash water.
- ◆ Allow 3" clearance below system for filter cartridge removal and replacement.
- ◆ Detailed, illustrated installation guide is included with each system.

*Not performance tested or certified by NSF.

† When installed, serviced and maintained according to Pentair Everpure Installation Operation Instructions.

‡ Up to 50% recovery compared to standard RO systems with 25% recovery.

EPA Est. 002623-IL-003

EZ-RO™ 650/16ATM REVERSE OSMOSIS SYSTEM

EV9975-70

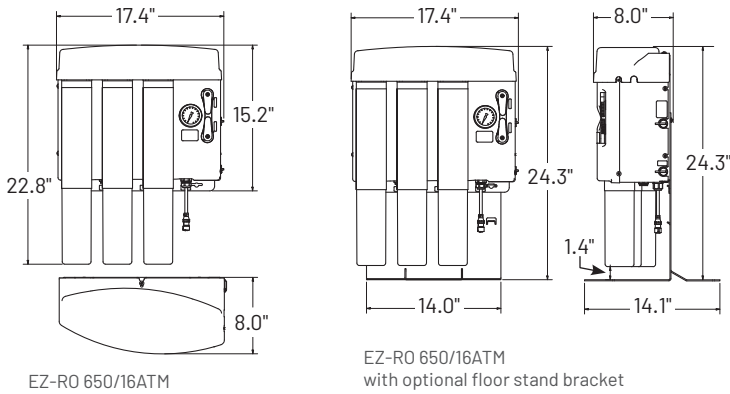

EZ-RO 650/16ATM

EZ-RO 650/16ATM with optional floor stand bracket

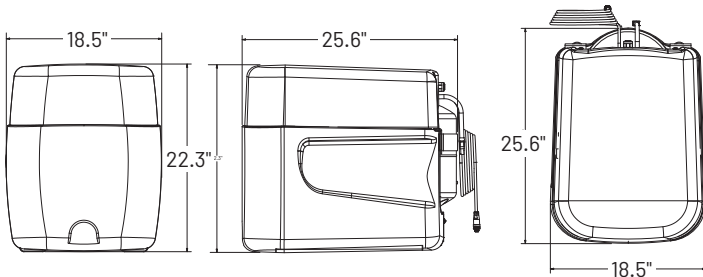

16-gallon atmospheric tank



System is Tested and Certified by NSF International against NSF/ANSI 58 and CSA B483.1 for the reduction of Total Dissolved Solids (TDS).



SPECIFICATIONS

System

Overall Dimensions - Processor
22.8" H x 17.4" W x 8.0" D
(57.9 cm x 44.2 cm x 20.3 cm)

Tank Dimensions & Capacity
22.3" H x 18.5" W x 25.6" D
(56.6 cm x 47.0 cm x 65 cm)
16 gallons (60.6 L)

Connections

Inlet: 3/8" push-to-connect
Outlet: 1/2" OD push-to-connect;
3/4" garden hose connection included

Pressure Requirements

50 - 100 psi
(3.5 - 6.9 bar), non-shock

Water Temperature

40-100°F (4 - 38°C)

System

Shipping Weight
74.0 lbs (33.6 kgs)

Electrical Connection
Grounded 115 VAC, 2 Amp

Performance

Daily Production Rate
Up to 650 gpd (2,460 Lpd)*
nominal at 77°F (25°C), 750 ppm NaCl, 60 psi (4.1 bar) feed water pressure*; production will vary based on water supply temperature and pressure

Service Flow Rate

Dependent on water level up to 3.25 gpm (12.3 L) @ 50 psi (3.4 bar)

*Not performance tested or certified by NSF.

OPTIONS

Model	Description	Part No
PRV	Pressure reducing valve	164-89938
BPS-QT	Booster pump assembly	164-85020
Air Gap Kit	Air gap approved for drain	164-89905
EZFS	Floor stand bracket	EV3159-68
Mixing Valve	Thermostatic mixing valve	EV3114-79

REPLACEMENT CARTRIDGES

Model	Qty	Description	Part No
7FC5-S	1	Prefilter	EV9693-71
EZ-650	1	RO membrane	EV9628-94
7CM	1	Mineral addition	EV9627-85

It is recommended that pre-/post-filters and mineral addition cartridges are changed every six (6) months, when capacity is reached, or when feed water pressure or flow becomes inadequate.

The contaminants or other substances removed or reduced by this drinking water system are not necessarily in your water. Do not use with water that is microbiologically unsafe or of unknown quality without adequate disinfection before or after the system.

Since the conditions under which our products may be used are beyond our control, we cannot accept any liability with respect to the improper installation, application and/or use of our products.

For Pentair Everpure Product Warranties visit:
<http://pentair.com/assets/foodservice-warranty>

For Pentair Patent Information visit:
<http://pentair.com/patents>



United States | 1040 Muirfield Drive | Hanover Park, IL 60133 | 800.942.1153 (US Only) 630.307.3000 Main | cseverpure@pentair.com | foodservice.pentair.com
Australia | 1-21 Monash Drive | Dandenong South, Vic 3175 | Australia | 011.1300 576 190 Tel | au.everpure@pentair.com
China | 21F Cloud 9 Plaza, NO 1118 | Shanghai, 200052 | China | 86.21.3211.4588 Tel | china.water@pentair.com
India | Boulevard, B-9/A, 7th Floor - Tower B Sector 62 | Noida - 201301 | 91.120.419.9444 Tel | indiacustomer@pentair.com
Europe | Pentair Water Belgium BV | Industriepark Wolfstee, Toekomstlaan 30, B-2200 Herentals | Belgium | +32.(0).14.283.504 Tel | sales@everpure-europe.com
Japan | Japan Inc. | Hashimoto MN Bldg. 7F, | 3-25-1 Hashimoto, Midori-ku, Sagami-hara-shi | Kanagawa 252-0143 | Japan | 81.(0)4.2775.3011 Tel | info@everpure.co.jp
Southeast Asia | 390 Havelock Road, | #04-01 King's Centre | Singapore 169662 | 65.6768.5800 Tel | cseverpure@pentair.com

All indicated Pentair trademarks and logos are property of Pentair. Third party registered and unregistered trademarks and logos are the property of their respective owners.